

HCP PUMP

Model	80SA22.2
Series	SA
Frequency	50
Phase	3
Discharge	80 mm (3")



Motor Data

Input Power—P1	2.95 kW
Rated Power—P2	2.2 kW
Insulation Class	F
Voltage Range	200~525V
Max. Starts Per Hour	10
Rated Speed (rpm)	2840
Start Method	DOL
Ingress Protection Code	DOL
Explosion-Proof	IP68

Technology

Impeller Type	Open
Mechanical Seal	Double
Lubricating Oil VG32	850 CC
Solid Passage	20 mm
Cooling Type	External cooling

Material

Motor Frame	SUS316 (AISI 316)
Shaft	SUS316 (X5CrNiMo17-12-2)
Casing	SCS14 (G-X6CrNiMo1810)
Impeller	SCS14 (G-X6CrNiMo1810)
Mechanical Seal	CA/CE&SiC/SiC
Cable	VCT,H07RN-F
Upper and Lower Bearing	6204ZZ,6305ZZ

Liquid

Maximum Ambient Temperature	0~40°C (32~104°F)
Maximum Installation Depth	20m (66ft)
Highest Liquid Temperature	40 °C (104°F)
Liquid Transported	Acid and alkali sewage

Others

Protection Device	Auto-cut Protector
Moisture Sensor	



HCP PUMP

PUMP PERFORMANCE CURVES

Model	80SA22.2	File NO.	20210210215428
Frequency	50 Hz	Ver NO.	202003060911
Discharge	3" / 80 mm	REFERENCE SPECIFICATION	
Output	3 HP / 2.2 kW	Output	2.01 kW
Std. Head	12.5 m	Efficiency	63.3 %
Std. Capacity	36 m ³ /h		
Phase / Volt	3 Ø / 380 V		
Rated Current	5.10 A		
Pole / rpm	2 P / 2840 rpm		
Start Method	DOL		
Insulation Class	F		

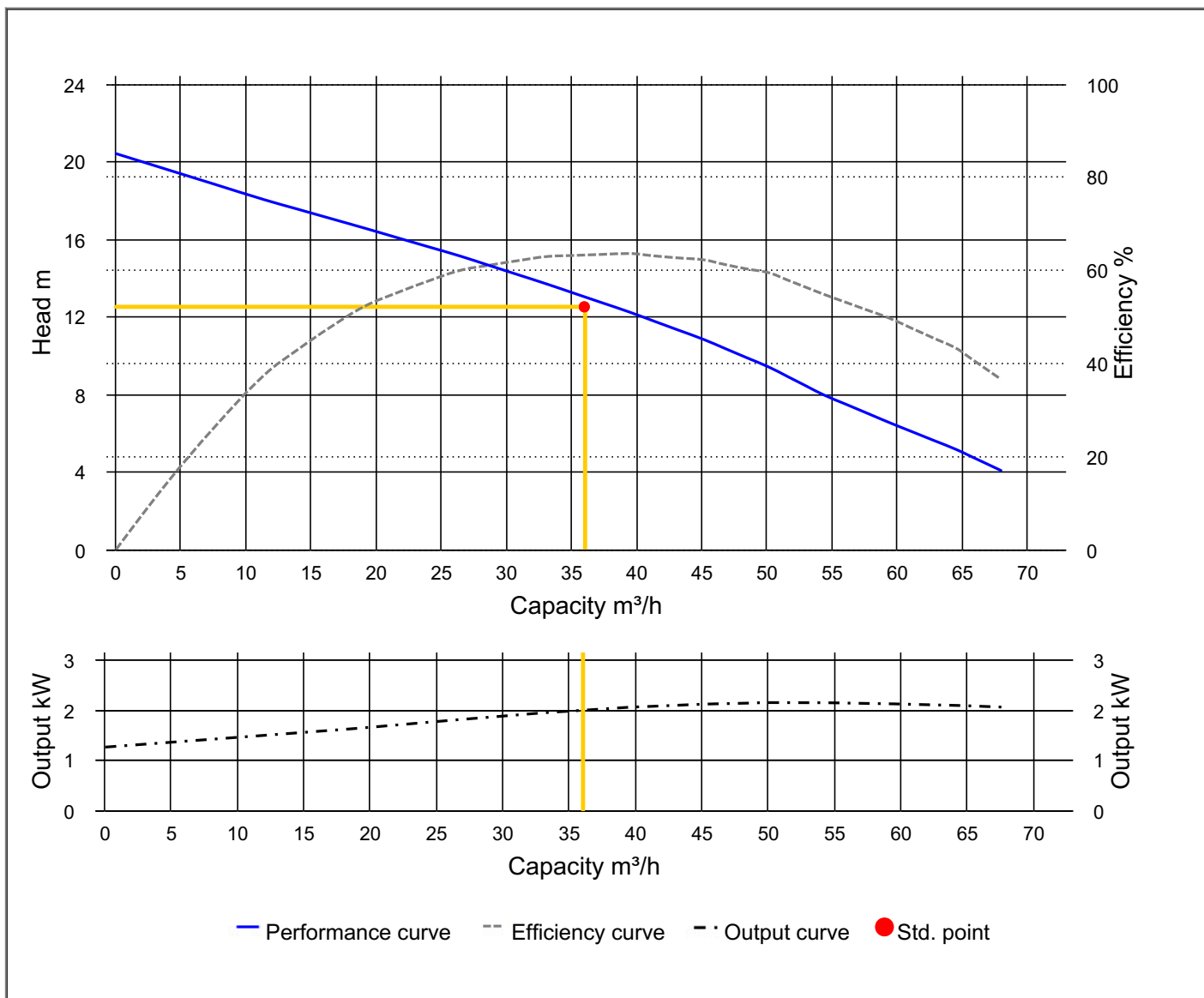

DIMENSIONS

NO: S3SA0222030-00

MODEL: 80SA21.5 / 22.2

50Hz 1Ø / 3Ø

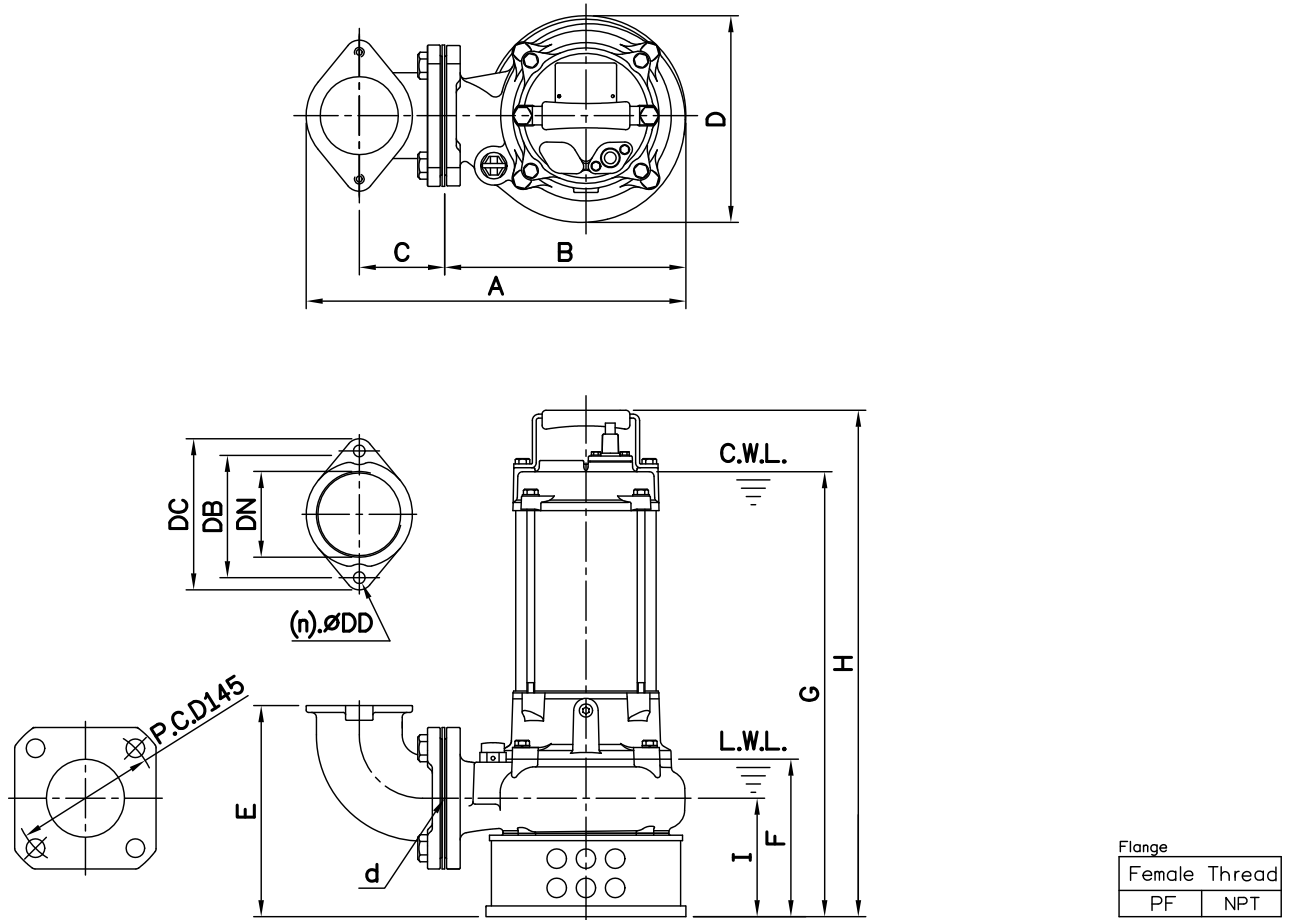

Dimensions—mm

Weight:kg

Model	d	A	B	C	D	E	F	G	H	I	WT1	Elbow (Flange)Set	DN	DB	DC	DD	(n)QTY	WT2
80SA21.5 1Ø	80	390	248	88	212	217	162	526	589	122	34	ESB3-130K	80	130	155	12	2	4
80SA21.5 3Ø	80	390	248	88	212	217	162	457	520	122	30	ESB3-130K	80	130	155	12	2	4
80SA22.2 1Ø	80	390	248	88	212	217	162	538	601	122	38	ESB3-130K	80	130	155	12	2	4
80SA22.2 3Ø	80	390	248	88	212	217	162	457	520	122	33	ESB3-130K	80	130	155	12	2	4

Dimensions—inch

Weight:lb

Model	d	A	B	C	D	E	F	G	H	I	WT1	Elbow (Flange)Set	DN	DB	DC	DD	(n)QTY	WT2
80SA21.5 1Ø	3	15 ³ / ₈	9 ³ / ₄	3 ⁷ / ₁₆	8 ³ / ₈	8 ⁹ / ₁₆	6 ³ / ₈	20 ⁷ / ₁₆	23 ³ / ₁₆	4 ⁹ / ₁₆	75	ESB3-130K	3	5 ¹ / ₂	6 ¹ / ₈	1/2	2	9
80SA21.5 3Ø	3	15 ³ / ₈	9 ³ / ₄	3 ⁷ / ₁₆	8 ³ / ₈	8 ⁹ / ₁₆	6 ³ / ₈	18	20 ¹ / ₂	4 ⁹ / ₁₆	66	ESB3-130K	3	5 ¹ / ₂	6 ¹ / ₈	1/2	2	9
80SA22.2 1Ø	3	15 ³ / ₈	9 ³ / ₄	3 ⁷ / ₁₆	8 ³ / ₈	8 ⁹ / ₁₆	6 ³ / ₈	21 ¹ / ₁₆	23 ³ / ₁₆	4 ⁹ / ₁₆	84	ESB3-130K	3	5 ¹ / ₂	6 ¹ / ₈	1/2	2	9
80SA22.2 3Ø	3	15 ³ / ₈	9 ³ / ₄	3 ⁷ / ₁₆	8 ³ / ₈	8 ⁹ / ₁₆	6 ³ / ₈	18	20 ¹ / ₂	4 ⁹ / ₁₆	73	ESB3-130K	3	5 ¹ / ₂	6 ¹ / ₈	1/2	2	9

C.W.L.:Continuous Running Water Level
L.W.L.:Lowest Running Water Level

WT1:Pump Weight(Without Cable)
WT2:Elbow Set Weight

DIMENSIONS

NO: T3SA0222030-00

MODEL: 80SA21.5 / 22.2

50Hz 1Ø / 3Ø

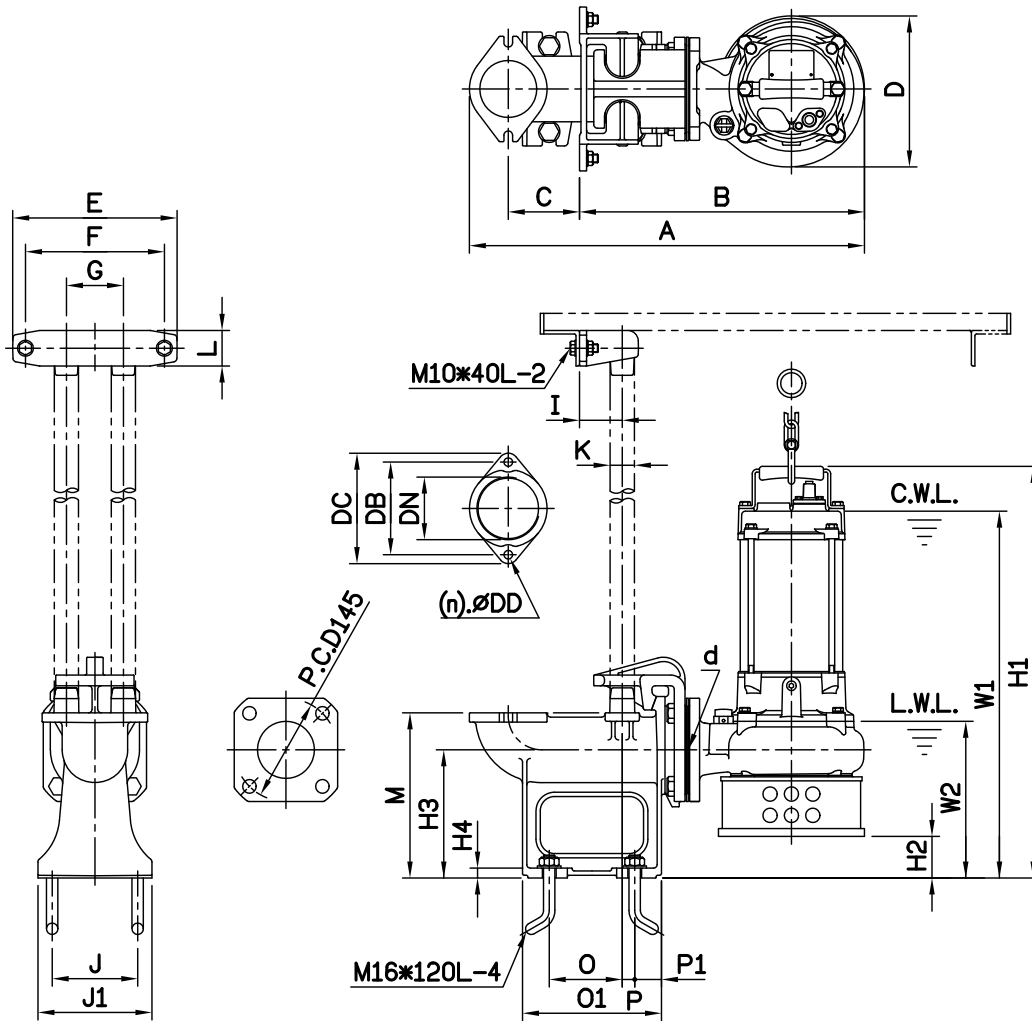

Flange	
Female Thread	
PF	NPT

Dimensions-mm

Elbow (Flange)Set	DN	DB	DC	DD	(n)QTY
ESF3-130	80	130	155	12	2

Dimensions-inch

Elbow (Flange)Set	DN	DB	DC	DD	(n)QTY
ESF3-130	3	5 1/8	6 1/8	1/2	2

Dimensions-mm

Model	d	A	B	C	D	E	F	G	I	J	J1	K	L	M	O	O1	P	P1	W1	W2	H1	H2	H3	H4	WT1	Weight:kg	
																										GRS Set	WT2
80SA21.5 1Ø	80	555	400	100	212	230	195	80	60	120	160	1 1/4	50	232	103	195	18	38	584	220	647	59	180	14	34	ST2-80	19
80SA21.5 3Ø	80	555	400	100	212	230	195	80	60	120	160	1 1/4	50	232	103	195	18	38	515	220	578	59	180	14	30	ST2-80	19
80SA22.2 1Ø	80	555	400	100	212	230	195	80	60	120	160	1 1/4	50	232	103	195	18	38	596	220	659	59	180	14	38	ST2-80	19
80SA22.2 3Ø	80	555	400	100	212	230	195	80	60	120	160	1 1/4	50	232	103	195	18	38	515	220	578	59	180	14	33	ST2-80	19

Dimensions-inch

Model	d	A	B	C	D	E	F	G	I	J	J1	K	L	M	O	O1	P	P1	W1	W2	H1	H2	H3	H4	WT1	Weight:lb	
																										GRS Set	WT2
80SA21.5 1Ø	3	21 7/8	15 3/4	3 15/16	8 3/8	9 1/16	7 1/16	3 1/8	2 3/8	4 3/4	6 1/16	1 1/4	2	9 1/8	4 1/16	7 1/16	1 1/16	1 1/2	23	8 11/16	25 1/2	2 3/16	7 1/16	5/16	75	ST2-80	42
80SA21.5 3Ø	3	21 7/8	15 3/4	3 15/16	8 3/8	9 1/16	7 1/16	3 1/8	2 3/8	4 3/4	6 1/16	1 1/4	2	9 1/8	4 1/16	7 1/16	1 1/16	1 1/2	20 1/4	8 11/16	22 3/4	2 3/16	7 1/16	5/16	66	ST2-80	42
80SA22.2 1Ø	3	21 7/8	15 3/4	3 15/16	8 3/8	9 1/16	7 1/16	3 1/8	2 3/8	4 3/4	6 1/16	1 1/4	2	9 1/8	4 1/16	7 1/16	1 1/16	1 1/2	23 1/8	8 11/16	25 15/16	2 3/16	7 1/16	5/16	84	ST2-80	42
80SA22.2 3Ø	3	21 7/8	15 3/4	3 15/16	8 3/8	9 1/16	7 1/16	3 1/8	2 3/8	4 3/4	6 1/16	1 1/4	2	9 1/8	4 1/16	7 1/16	1 1/16	1 1/2	20 1/4	8 11/16	22 3/4	2 3/16	7 1/16	5/16	73	ST2-80	42

C.W.L.:Continuous Running Water Level
L.W.L.:Lowest Running Water Level

WT1:Pump Weight(Without Cable)
WT2:GRS Set Weight

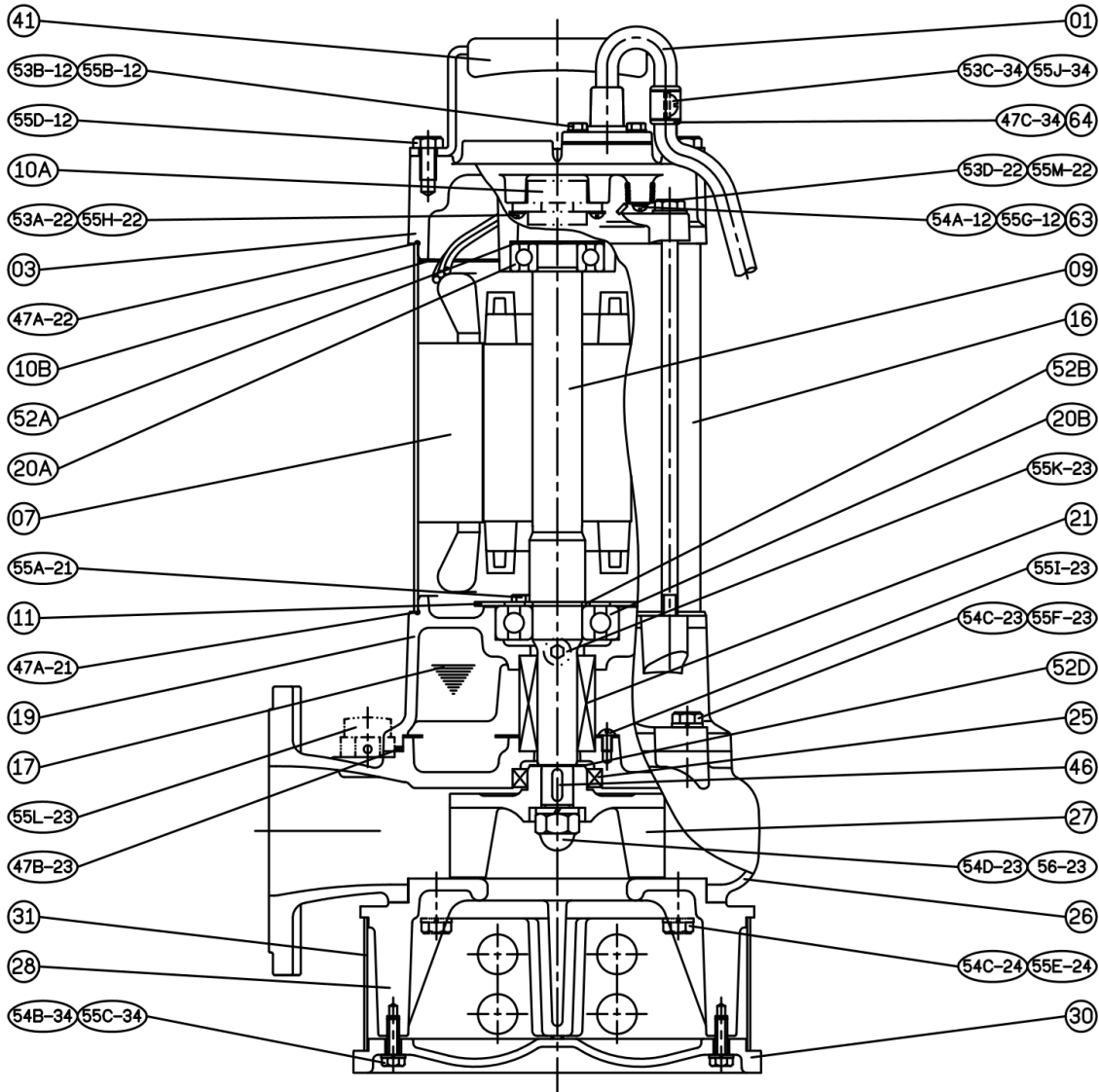

NO.	Part name	Material	QTY
01	Cable		1
03	Upper Cover	SCS14	1
07	Stator		1
09	Shaft End	SUS316	1
10A	Auto-cut Protector		1
10B	Protective Plate		1
11	Bearing Fixer	SPCC	1
16	Motor Frame	SUS316	1
17	Lubricant		
19	Bearing Bracket	SCS14	1
20A	Bearing		1
20B	Bearing		1
21	M. Seal	CA/CE & SiC/SiC	1
23	M. Seal Bracket	SCS14	1

NO.	Part name	Material	QTY
25	Oil Seal	NBR	1
26	Casing	SCS14	1
27	Impeller	SCS14	1
28	Casing Cover	SCS14	1
30	Footing	SCS14	1
31	Strainer	SUS316	1
41	Handle	SUS304	1
46	Impeller Key	SUS304	1
47	Gasket Kit		